



 **neodrives**

T H E R E A R M O T O R

Z 20

MADE IN GERMANY



Inhalt

01	WHO ARE WE	3
02	MADE IN GERMANY	3
03	NEODRIVES REAR MOTOR	4
04	ADVANTAGES OF REAR MOTORS	4
05	SUSTAINABILITY	5
06	TORQUE	6
07	IMPORTANTE NOTES	7
08	<i>SIMPLYREMOTE</i>	8
	08.1 Scope of delivery / components	8
	08.2 Installation and commissioning	9
	08.3 Using the <i>simlyRemote</i>	10
09	<i>SIMPLYRIDE APP</i>	12
	09.1 Downloading and installing the simplyRide app	12
	09.2 Using the simplyRide app	16
10	NEODRIVES REAR MOTOR	18
	10.1 Technical data	18
	10.2 Motor	18
11	BATTERIE	20
	11.1 Standard equipment	20
	11.2 Technical specifications	20
	11.3 Key elements at a glance	21
	11.4 Safety instructions and warnings	22
	11.5 Getting started	26
	11.6 Removing the battery	28
	11.7 Charging the battery	29
	11.8 Key	30
	11.9 Cleaning the battery	30
	11.10 Disposal	31
	11.11 Liability	31
12	CHARGER	32
	12.1 General safety information	32
	12.2 Charger functions	32
	12.3 Operation	32
	12.4 Remarks	32
	12.5 Scope of delivery	32
13	NOTES AND TROUBLESHOOTING	33
	13.1 Cleaning	33
	13.2 Transportation	33
	13.3 Fault symptoms and possible measures	34
	13.4 Warnings on the <i>simplyRemote</i>	34
	13.5 Error symptoms	35

01 | WHO ARE WE

SINCE 2012 NEODRIVES HAS BEEN THE E-BIKE BRAND OF ALBER GMBH

Neodrives is the e-mobility brand of Alber GmbH. We develop and produce high quality drive systems for the leisure segment, especially for e-bikes, under the brand name neodrive.

For over 25 years Alber has specialized in the development, production and distribution of highly integrated electric drive units, energy storage systems and electronic controls for medical technology.

02 | MADE IN GERMANY

AT HOME IN GERMANY

Almost 500 employees develop and manufacture electric motors for the bicycle and rehabilitation industries at Alber GmbH.

EVERYTHING FROM A SINGLE SOURCE

The neodrive drive system is developed in-house from A to Z. Assembly is also carried out 100% in Albstadt. The development focus is on maximising drive performance.

A close and sustainable relationship with our suppliers and local partners is very important to us. Together with our suppliers we pursue the goal of producing the best pedelec motor on the market with outstanding riding characteristics.

All development and production takes place in Albstadt, Baden-Württemberg. Most of the raw materials are produced in Germany. It is our conviction that Germany will remain a manufacturing base for the future.



03 | NEODRIVES REAR MOTOR

Z20

The Z20 rear motor is the latest addition to neodrives' pedelec range. Experience from the previous generation has been incorporated into the new development. The drive unit has been completely redesigned. The advantages of the Z20, such as the direct handling and the powerful acceleration of the rear wheel drive, have been emphasised. Thanks to the innovative machine winding, heat-conducting materials and new sensor technology, heat generation is no longer an issue. As a reliable partner in everyday life, the Z20 drive takes commuters to work and scores points for being maintenance-free even in continuous use. In your free time, the Z20 will provide you with a lot of fun when touring.

REAR MOTOR Z 2 0

up to

20 KM/H



04 | ADVANTAGES OF REAR MOTORS

QUIET OPERATION

No other drive system runs as quietly and with as little vibration as neodrives.

POWERFUL

The power of the rear motor ensures direct and linear response with rapid acceleration.

LOW WEAR

Mounting the motor close to the rear wheel reduces wear on the chain, sprocket and crank arm.

ENERGY RECOVERY

The battery recharges as you ride downhill.

EASE OF USE AND COMPATIBILITY

Long-term availability of spare parts for standard bicycle components.

0 5 | SUSTAINABILITY

SUSTAINABLE E-BIKING

Sustainable behaviour starts with each individual - Alber wants to make its contribution as a company. Our focus is on a responsible approach to the environment and a fair relationship with our employees and business partners.

CONSERVING RESOURCES

When riding with a Neodrives system, the direct drive and gearless motor ensures low material stress. The rear wheel drive takes the strain off the chain, sprocket and crank arm. This means less wear and tear and longer maintenance intervals, which is good for your wallet and good for the environment.

ENERGY RECOVERY

With a Neodrives motor you can make active use of energy recovery. This protects the brakes and recharges the battery while you drive.

DURABLE MATERIAL

Our drive concepts are always durable and extremely robust. A high-quality motor connector, an elaborately powder-coated aluminium motor housing and sophisticated system electronics guarantee long-lasting driving pleasure.

SHORT ROUTES; PRODUCTION FROM THE REGION

Alber wants to keep transport routes short. This is why many of our suppliers and business partners are located in Germany or neighbouring European countries. This helps to maintain Germany/EU as a production location and stabilises the value chain.

ISO 14001 : 2015 CERTIFICATION

Alber meets the standard for environmental management.

EASE OF REPAIR

Should an Alber drive unit ever fail, we have a large stock of spare parts. This means that even older e-bikes can be repaired quickly and sustainably.

Seit 2012 ist Alber "Green Company"

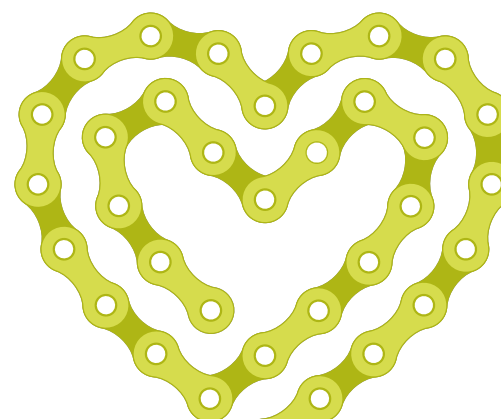

06 | TORQUE

THE REAR MOTOR HAS A POWER OUTPUT INDEPENDENT OF THE GEAR RATIO

If you compare the data sheets of the mid-engines, you will find values of up to 90 Nm torque. This does not mean that the mid-motor is more than twice as powerful as the Neodrives rear motor. The torque actually delivered by the mid-motor to the rear wheel is greatly influenced by the gear ratio. For example, a gear ratio of 38 chainrings and 19 sprockets - the range most riders use - halves the torque available at the rear wheel. In addition, hub gears in particular cannot withstand the high torques over a long period of time, which is why mid-drive motors are throttled at the factory. Another point to bear in mind is that the high torque puts a lot of stress on the chain, which drastically reduces its life.

OUR TIP:

Test ride all systems. You will hardly notice any difference in performance when you compare high-quality mid-mounted motors with the Neodrives rear motor. In fact, due to the position of the motor in the rear wheel, the rear motor feels much more powerful.

As already mentioned, the maximum torque of 40 Nm is always available to the rider regardless of the gear selected. With the mid-mounted engine, the torque is reduced by the gear selected, so that in some cases only half of the torque reaches the rear wheel.

TORQUE [NM]*

The torque of the mid-mounted engine can be greatly reduced by the gear ratio.

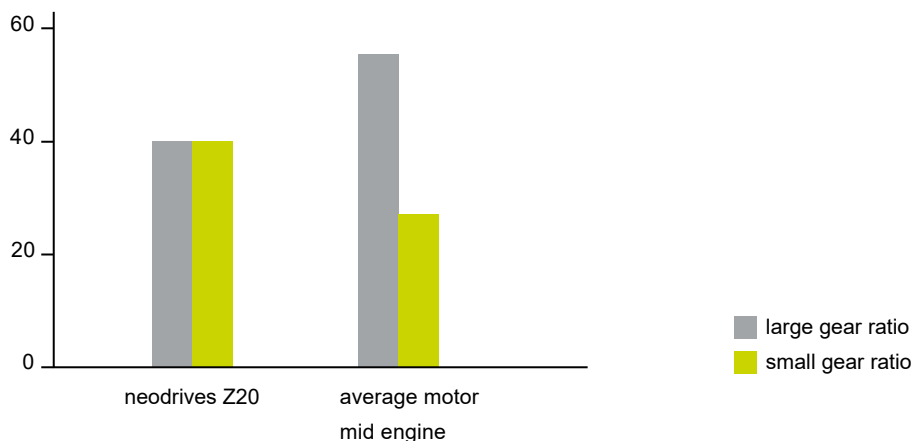

* at a speed of 18 to 25 km/h.

07 | IMPORTANT NOTES

In addition to this manual, your pedelec comes with other documents. Please follow the specifications and instructions in these documents. There is currently no legal requirement to wear a helmet when using a pedelec. However, it is recommended that you wear a helmet for your own safety!

Intended use of neodrives components

Your pedelec is equipped with neodrives components and is designed for normal passenger transport on public roads.

Adjustments and repairs to the pedelec and the individual components are only considered to be intended use if they are explained and authorised in this user manual, in the pedelec manufacturer's user manual, in the component manufacturer's instructions or in other documents supplied with the pedelec.

The manufacturer accepts no liability for damage caused by negligent handling, improper maintenance, improper repairs or improper use. It is the rider's responsibility to have the pedelec inspected and serviced as prescribed and to use it responsibly.

This manual only describes the use of the neodrives components installed in your pedelec and reflects the state of the art at the time of printing. The manufacturer reserves the right to make changes resulting from further development of the mechanics, software or legal requirements.

The manufacturer considers the following cases, among others, to be misuse of the neodrives components fitted to your pedelec:

- Use of the drive system contrary to the instructions and recommendations in this manual.
- Exceeding the technical performance limits defined in this manual.
- Technical modifications to neodrives components.
- Modifications to the software of the neodrives components.
- Unauthorised installation or use of the neodrives components on a bicycle or pedelec other than the one supplied to you.

The manufacturer accepts no liability for damage resulting from misuse of the components.

Familiarise yourself with the safety and hazard information in the individual chapters of this operating manual and all other enclosed documents before starting your journey.

Operate the *simplyRemote* during the journey only to set the support levels or to display the charge status; for further operation, stop the vehicle and make the appropriate settings.

Warnings

Warning of possible health hazards, indication of possible risk of injury; warning of possible technical problems or damage. It is essential that you follow these instructions to avoid personal injury and damage to the product.

- If possible, do not expose your pedelec to strong sunlight for long periods when not in use. This will cause the motor to heat up and, in extreme cases, it will not be able to deliver its full power. Plastic parts also age faster in strong sunlight.
- If the system comes to a standstill due to high temperatures (e.g. from continuous driving or standing in direct sunlight), allow the engine to cool down for about 10 minutes before continuing your journey.
- The maximum speed (non-motorised operation) of the system is 75 km/h. If this speed is exceeded, the electrical components may be damaged. The maximum speed is recorded by the system.

Permissible operating conditions / locations

The neodrive components can be operated at temperatures between -20°C and +60°C → see Table 1: *simplyRemote* technical data. Please also refer to the information on permissible operating conditions in the pedelec manufacturer's user manual. When using the pedelec, you must also observe the limitations of the permissible operating conditions (e.g. maximum climbing ability, maximum permissible obstacle height, maximum user weight)! Observe the safety and hazard warnings in the individual chapters of this user manual.

08 | SIMPLYREMOTE

The new *simplyRemote* (see Figure 1) is a user interface for the neodrive systems Z20 (e-bike up to 25 km/h) and Z20 S systems. It offers intuitive operation thanks to its simple display and limitation to the essential functions.

8.1 Scope of delivery / components

There are five keys on the *simplyRemote* (see Figure 1: *simplyRemote*), which are easy to use due to their size and coating. In addition, there are 5 LEDs in the centre of the *simplyRemote* for a simple display to make operation easier for the user.



Figure 1: *simplyRemote*

An additional adapter cable is used to connect the *simplyRemote* to the e-bike's wiring harness. Depending on the type of battery, a neodrive connector (see Figure 2, left) or a JST connector (see Figure 2, right) is used. The JST connector is used for all integrated batteries and the neodrive connector is only used for the external neodrive V2 battery.

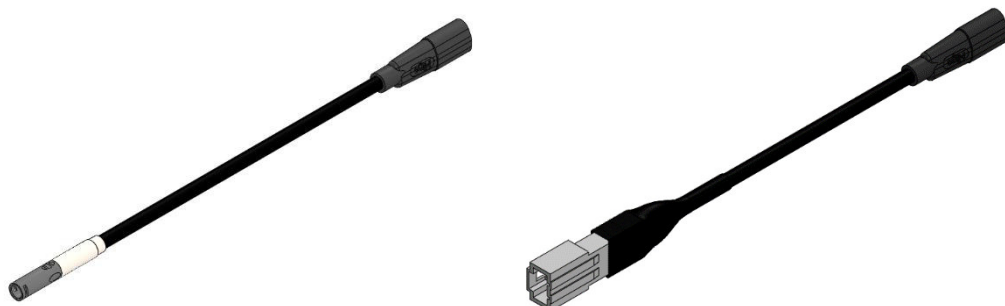

Figure 2: *simplyRemote* adapter

simplyRemote	
Interface	Bluetooth (BLE)
Operating temperature	-20 bis +60°C
Storage temperature	-40 bis + 65°C
Protection class	IP 65
Clamping diameter	22,2 mm
Fastening torque	max. 1 Nm

Table 1: *simplyRemote* technical data

8.2 Installation and commissioning

To start up your e-bike, please read the user manual of the respective system. Please consult a specialist dealer for correct installation of the *simplyRemote* control unit.

To switch on the system, press the 'On/Off' button once briefly (1 second) (see Figure 3: *simplyRemote* illustration), all five LEDs will light up three times briefly in white. The start-up process takes six seconds.



Figure 3: *simplyRemote* illustration

Note: With the BMZ UR-V2 battery version (additional battery), the e-bike must be switched on using the on/off button on the battery. After a standby time of 4 hours, the V2 battery goes into 'deep sleep' and must be woken up by pressing the battery button.

Notes:

Please remove your weight from the pedal when switching on. Only pedal when the *simplyRemote* is fully switched on and the white LEDs are permanently lit. Do not switch on the system or put any weight on the pedal while riding. If the system is switched on while driving, the second lowest LED on the *simplyRemote* will light up orange. Please release the pedal until the LED is no longer illuminated, then you can continue your journey with the assistance of the engine.

Please remember to switch off the pedelec with the remote control after every ride.

8.3 Using the *simplyRemote*

When the e-bike is switched on, the green LEDs light up first (2 seconds), then the white LEDs light up continuously. The green LEDs indicate the selected assistance level, the last selected assistance level is automatically reset. The white LEDs indicate the state of charge of the battery. You can switch between the views using the 'SET' button, except when you are connected to the *simplyRide* app.

„+“-button:

- Increase the level of assistance (5 LEDs = 5 levels of assistance) by pressing the button.
- Activate the pushing assistance (4 km/h): Press and hold the button for 4 seconds, release and confirm by pressing and holding the '+' button (or '-' for reverse assistance). (Attention: The reverse push aid is only activated with the corresponding engines).

„-“-button:

- Downshifting the assistance level
- Activate regenerative braking (only possible above 6 km/h (blue LED))

LED-display:

- White flashing LED: System is on
- Green LED display: Support levels
- White LED indicator: Battery charge status (5 white LEDs = battery fully charged)
- Blue flashing LED Pairing process
- Fault diagnosis see 4.4 Warning display on the *simplyRemote*

„Light“-button:

You can recognise when the light is switched on by the intensity of the LED display. If the LEDs light up more brightly, no lighting is switched on and if the LEDs on the display light up less brightly, the light of the e-bike is switched on.

The dimming of the LEDs can be set via the *simplyRide* app, e.g. if the LEDs are not recognisable in sunlight. If the light was switched on when the e-bike was last switched off, it is also switched on again when it is switched on again.

„**On/Off**“-button: Switching the e-bike on and off

„**SET**“-button Changing the views, battery charge status and assistance level. If the remote is connected to the app, the displayed values are switched through

8.3.1 Using a display

The *simplyRemote* does not need an additional display and shows all relevant information via the LED display, however the smartphone can be used as a display for the *simplyRemote*, see 3.2.3 Display. If you do not want to use your smartphone with the *simplyRide* app as a display, you can also use a Sigma bike computer as a display to show the speed or similar. Look for the 'E-Bike Ready' label when you buy.

8.3.2 neodrives system updates

You can perform all system updates for your neodrives components via your *simplyRide* app. All information on installation and use can be found in chapter 3.2.5 neodrives system updates.

09 | SIMPLYRIDE APP

In addition to *simplyRemote*, there is also the *simplyRide* app, which can be used as a versatile tool. It offers the option of using the smartphone as a screen on the handlebars, customisation, evaluations and system updates. (The illustrations in the following chapter may vary depending on the published version of the *simplyRide* app).

9.1 Download and install the *simplyRide* app

Download the app:



Android: Google Playstore → *simplyRide*



IOS: Apple Store → *simplyRide*

Search for the *simplyRide* app and install it on your smartphone.

Step 1:

Select 'Connect e-bike'.

Step 2:

Switch on the e-bike and confirm this with 'My e-bike is switched on' in the app.

Step 3:

Press and hold the 'Set' and 'Plus' buttons on the *simplyRemote* simultaneously until their LEDs start flashing blue/white. Confirm the flashing blue/white LED in the app with 'Done'.

Step 4:

The app searches for available e-bikes and displays them on the screen. Now connect to the e-bike you want, press bike and press 'Connect' in the app.

Step 5:

Confirm the pairing request from the application with 'Yes'. The LEDs on the *simplyRemote* will now start flashing faster and you can confirm the connection by pressing the 'SET' button again.

Step 6:

Confirm the pairing of the e-bike and the app using your smartphone by confirming 'pair'. It depends on the smartphone whether a pin is displayed or not. Just press 'Pair' to connect.

Step 7:

Your neodrives e-bike is now connected to the *simplyRide* app. Enter a name for your bike and complete the installation. The name you choose here is not important and will only be stored in the *simplyRide* app.

9.2 Using the *simplyRide* App

9.2.1 Connecting the E-Bikes

If you have already connected your e-bike to the *simplyRide* app, you do not need to add it as a new device when you use it again. When the e-bike is switched on and the *simplyRide* app is opened, the e-bike is automatically connected. All you have to do is tap 'Connect' on the home screen of the *simplyRide* app. Bluetooth and the location of your smartphone must be activated for the app to connect to the e-bike.

9.2.2 Setting options

Support levels & Speed

9.2.3 Display

You can use your smartphone as a display on your e-bike by attaching it to the handlebars with a commercially available smartphone holder. Operating your smartphone while riding is dangerous and should only be done when stationary. The 'SET' button on the *simplyRemote* allows you to switch between the different displays while riding, so you don't have to take your hand off the handlebars and take any risks. Once paired, you can only use the 'SET' button to change the views in the app and not the LED display on the *simplyRemote*.

The possible screens are:

- Screen: Speed, assist levels/recovery, cadence (determined by the motor)
- Statistics (average speed, distance, watts motor/human, ride time and kilometres)

9.2.4 Pairing with other devices

The *simplyRemote* can pair with up to four Bluetooth devices at the same time, as well as with broadcast signals (such as the SKS pressure sensor).

- Smartphone
- External screen (Sigma EOX View 1300)
- Gearbox (bspw. Pinion)
- Heart rate monitor
- Tyre pressure sensor (SKS pressure sensor)

system updates

Step 1:

The availability of system updates is displayed directly. 'Install Now' and follow the instructions. The update will now be installed.

Step 2:

The *simplyRemote* flashes during the update. The update will be transferred first. After the successful transfer, you can start the installation with 'OK'. During this time, the *simplyRemote* flashes to indicate the progress (1 LED = 20 %). The update time depends on how many and which components are included in the update and can take up to 15 minutes.

10 | NEO DRIVES REAR MOTOR

10.1 Technical data

Range*: Speed	120 km : 25km/h
Rated power (peak)	250 watts (650 watts)
Operating voltage Rated torque	36 volts
Peak torque	12 Nm
Efficiency	40 Nm
Control Power electronics	80% (including electronics)
Cassette holder	Integrated in the hub
Brake disk	Standard plug-in cassette, up to 10 speeds
Torque absorption Weigh	from 160 mm diameter Variable torque arm adaptable to dropouts 4.36 kg (drive unit only, including connectors and cables, excluding disc, freewheel and cassette)

Complete system

Operating temperature

Protection class

- 20°C to + 50°C (below 0°C the automatic disengagement of the recuperation of the brake assistant)
IP65 PROTECTION

(*) The range will vary depending on the battery used, the terrain and the riding conditions. The range indicated can be achieved under optimum riding conditions (e.g. level terrain, freshly charged batteries, ambient temperature of 20°C, smooth riding, etc.), a drive power of 100 watts and a pedal power of 100 watts.

Subject to technical and design changes due to continuous development.

This manual can be downloaded from our website www.neodrives.de. If you require a version with a larger font size, please contact the Alber Service Centre.

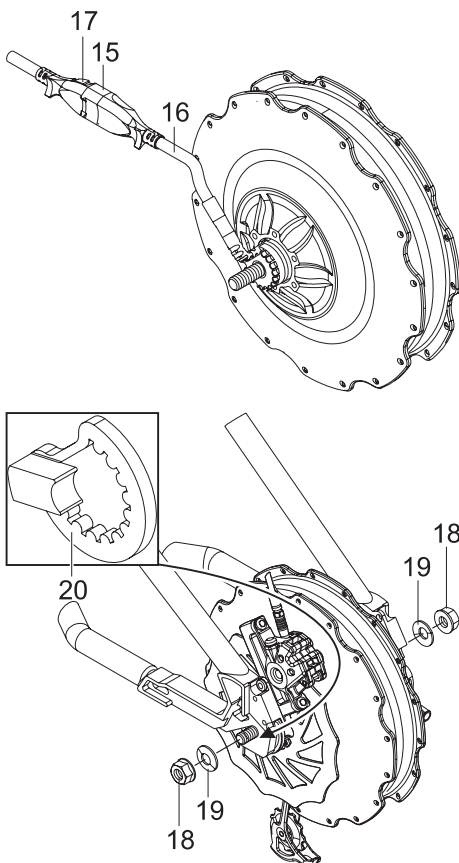

10.2 Motor

The drive wheel of your Pedelec can be removed from the bicycle frame at any time, for example for cleaning purposes or in the event of a flat tire. Proceed with extreme care when doing this and during subsequent assembly, paying particular attention to the instructions and information provided by the manufacturers of the various components attached to the bike, especially the brake disk. (Note: For reasons of clarity, only the drive motor integrated in the wheel is shown in the following diagrams, but not the complete drive wheel).

10.2.1 Removing the drive wheel

Before removing the drive wheel, make a note of the cable routing and the fixing points of the cable ties. First loosen and remove all cable ties securing the cable coming from the motor [16] as well as cables and supply lines of other components to the bicycle frame.

Then disconnect the plug [15] on the motor cable [16] from the socket [17] on the battery cable.

Loosen the two nuts [18] or the quick release with which the wheel is attached to the frame so that the complete wheel can be removed from the frame of your pedelec.

! Note or mark the position of the torque arm [20]. When the wheel is refitted, it must be in exactly the same position as before it was removed.

! Never hold or transport the removed wheel by the motor cable [16]. There is a risk of the cable breaking.

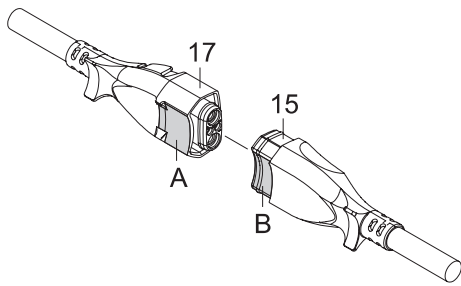

10.3 Fitting the rear wheel

Ensure that all components fitted to the wheel are fitted in accordance with the manufacturer's instructions and specifications. This applies in particular to the brake and the gearbox. Do not forget to reinstall the torque arm [20] in the same position in which it was previously removed.

Then slide the wheel into the frame mount and tighten the axle nut [18] in the following sequence:

- Tighten first on the shifting side (diagram A).
- Then on the brake side (diagram B).
-

The tightening torque for each nut is between 30 and 40 Nm. Make sure that the lock washer [19] is under the axle nut, otherwise there is a risk of the axle nut [18] coming loose.

If your wheels are fitted with quick release skewers, follow the manufacturer's instructions for fitting and tightening torque.

Once the wheel is correctly fitted to the frame, the motor can be connected to the end of the cable leading to the battery. Ensure that the plug [15] is correctly aligned with the socket [17]. The rounded surfaces ([A] and [B]) must be aligned! Use cable ties to secure all cables and supply lines to the frame and carry out a final function test.

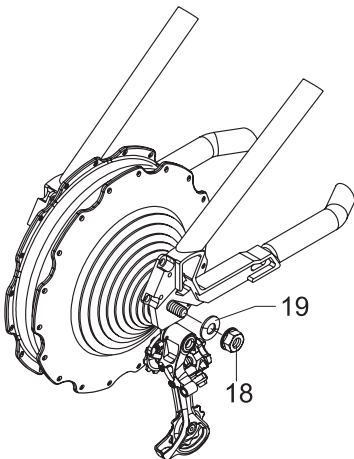
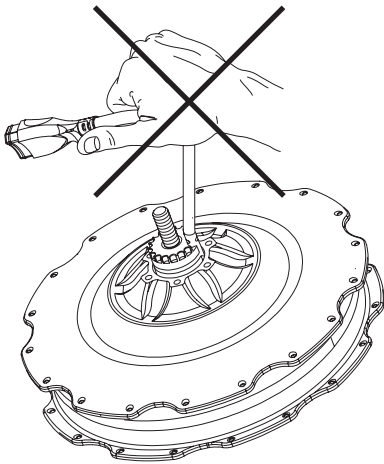

Make sure that the cable is routed correctly, as if it is routed incorrectly the cable may get caught in the brake disc, the drive or the spokes, causing the wheel to lock and result in an accident.



Always follow the instructions and specifications provided by the manufacturers of the various components fitted to the wheel. This applies particularly to brakes, gears and quick release skewers.

A



Never mount the motor without the torque arm [20]. This will result in total damage (twisting of the cable). This will invalidate all warranty and guarantee claims.



In addition to the repair tool, take 5 cable ties with you to securely reattach any cables that may come loose during a ride.



The best way to install or remove the rear wheel is to turn the pedelec upside down (on its handlebars and saddle). Remove the sMMI from the handlebars first to avoid damaging it.



Always use the sprocket sets originally fitted by the bicycle manufacturer. If other brands are used, the function of the sprocket set may be restricted or the sprocket set may rub on the rear triangle.

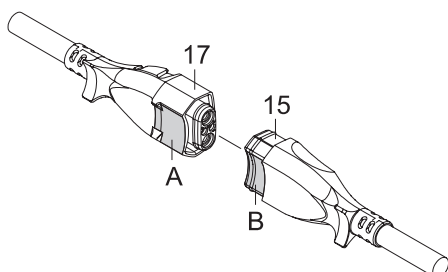
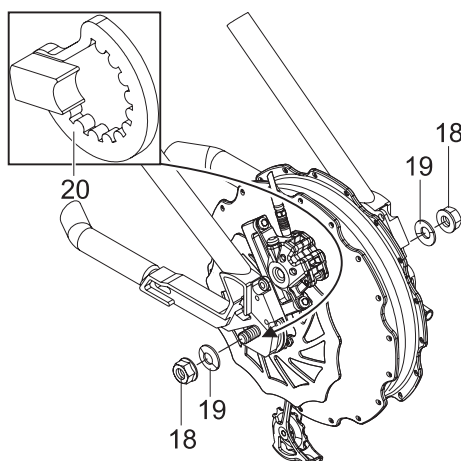

11 | BATTERY

11.1 Standard equipment (neodrives Komponenten)

- Battery incl. 1 pair of keys
- Battery holder (already mounted on the pedelec)
- User manual

11.2 Technical data

Cell:	BM18650Z3	ICR18650MG1	INR18650-35E
Battery type: Rated capacity: Rated voltage: Final charge voltage:	Lithium Ionen 11,25 Ah 37 V	Lithium Ionen 14,5 Ah 36,2 V	Lithium Ionen 17,25 Ah 36,2 V
Total energy: Maximum discharge current:	42,5 V 416 Wh	42 V 525 Wh	42 V 625 Wh
Charge ambient temperature:	30 A 0°C to 40°C	30 A 0°C to 40°C	30 A 0°C to 40°C
Ambient operating temperature:	-20°C to 60°C	-20°C to 60°C	-20°C to 60°C
Number of cells:	50	50	50
Number of cells:	IP54 approx.	IP54 approx.	IP54 approx.
Weight:	3,5 kg	3,5 kg	3,5 kg

Subject to technical and design changes due to continuous development. Please keep this manual for future information and reference.

Parameters related to electrochemical performance and durability

Rated Capacity	16 Ah	Charge: CC-CV 54.6 V – 3.6 A (0.2C) cut-off 0.36 A (0.02C) at 25 °C Discharge: CC 3.6 A (0.2C) to 32.5 V at 25 °C
Capacity loss	30%	After 600 cycles capacity of battery is 70%
Power	500W	Discharge current x Nominal voltage
Power loss	35%	ACIR increase (in %) after 600 cyc
Resistance	70 mΩ	ACIR (in Ohm): 1C-30Sec @50SOC%
Resistance increase	35%	DCIR increase (in %) after 600 cyc
Expected lifetime	600 cycles	6 jahre

BMZ Germany GmbH Zeche Gustav 1 D-63791 Karlstein
 am Main Company: BMZ Germany GmbH
 Address: Zeche Gustav 1, 63791 Karlstein, Germany
 Product: LMT Battery
 Description: V2 Z20 - Neodrive
 Article number: 617139

11.3 Key elements at a glance

Battery

Battery (housing)	1
Schlüssel	2
Charging socket / connection	3
Motor on/off button	4
LED display	5

Engine

Motor Cable	7
Plug Motor	8

Battery

Charger	9
---------	---

Charger cable
plug

On the pedelec

Battery rail	6
--------------	---

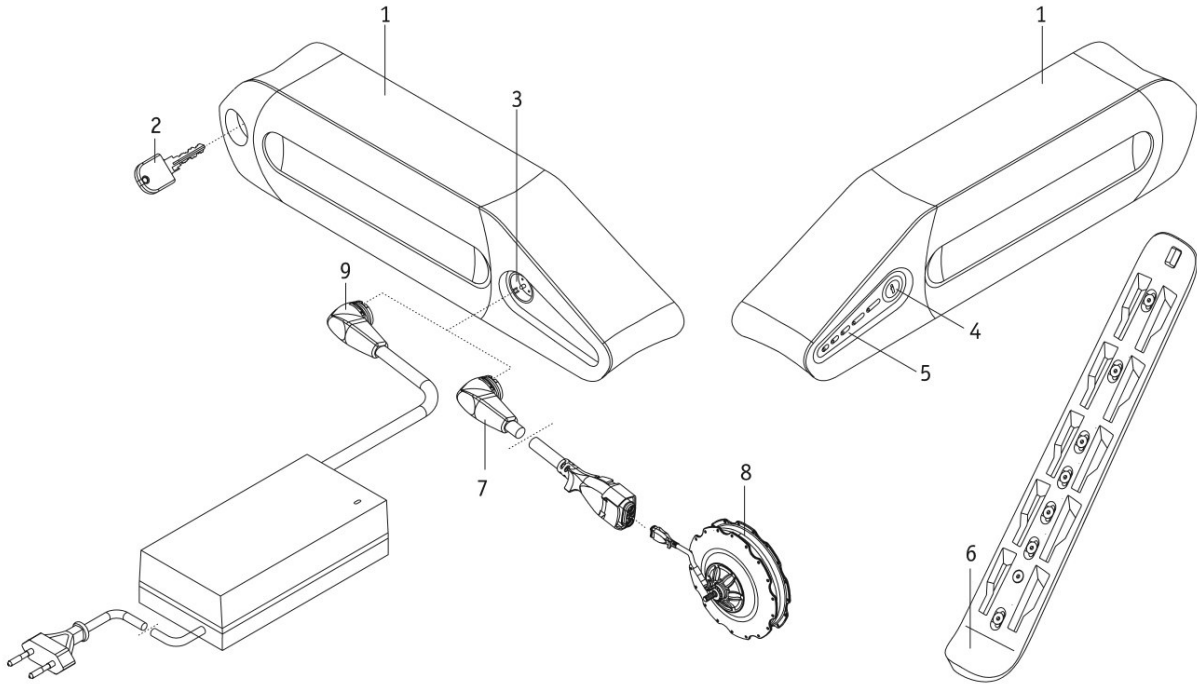

11.4 Safety instructions and warnings



Read and observe the following safety instructions and warnings before using or charging the battery. Failure to observe the safety warnings and instructions may result in damage to the product, electric shock, fire and/or serious injury. The lithium-ion battery contains chemical substances that can cause dangerous reactions if the safety instructions listed here are not observed. The manufacturer accepts no liability for damage caused by failure to comply with these instructions.

11.4.1 Safety and warning information on using the battery

- The battery should be fully charged before first use.
- The battery should only be used at temperatures between -20°C and 60°C.
- Do not expose the battery to heat (e.g. radiators) or fire. Exposure to external heat may cause the battery to explode.
- In the (unlikely) event of the battery overheating or catching fire, it must never come into contact with water or other liquids. The only reasonable extinguishing agent recommended by cell manufacturers is sand.
- Your pedelec consumes energy every time you use it. If possible, charge the battery after each use.
- The battery may only be used to power the Neodrives components. Any other use requires the written permission of the manufacturer.
- Do not open or disassemble the battery. Improper opening or vandalism of the battery may result in serious injury. In addition, opening the battery will invalidate the warranty.
- Never connect the contacts of the battery in the socket [3] to metallic objects or ensure that the contacts never come into contact with metallic objects (e.g. metal shavings).
- If the socket [3] is dirty, clean it with a clean, dry cloth.
- Do not immerse the battery in water.
- The life of the battery depends, among other things, on where it is stored. Do not leave the battery in a hot place for long periods of time (whether it is in or out of the pedelec). In particular, the boot of a car parked in the sun should only be used for transport and not as a general storage location.
- The battery must not be subjected to mechanical shocks. If, for example, the pedelec has fallen over and the battery has hit the ground directly, the battery must be checked by the manufacturer. Contact your dealer for this purpose. Do not use a damaged battery.
- If the battery is damaged or defective, it must be removed and inspected. Please contact your dealer for further information on return and repair. The defective/damaged battery must not be used or opened under any circumstances.
- Always ensure that the battery is kept clean and dry.

11.4.2 Safety instructions and warnings for storing the battery

- Protect the battery immediately after disconnecting it from the charger or engine. Do not allow moisture or foreign objects (e.g. metal splinters, small nails, shavings or other conductive metals) to enter the battery.
- Do not expose the battery to moisture (water, rain, snow, etc.) during storage!
- Charge the battery before storage and check the charge level every 3 months.
- Store the battery in a cool, dry place where it is protected from damage and unauthorised access.
- For optimum battery life, the battery should be stored at a temperature of 18°C to 23°C and a humidity of 0 to 80 percent. The battery should be 70% charged.
- When storing the battery, check the charge level every 3 months and recharge to 70% if necessary.

11.4.3 Safety and warning information on the charging process

- Only charge the battery in a ventilated, dry and dust-free environment.
- Never charge the battery in the presence of or near flammable liquids or gases.
- Do not expose the battery to moisture (water, rainwater, snow) during the charging process.
- Do not carry out the charging process in rooms where moisture could condense on the battery.
- The battery may only be charged at temperatures between 0°C and 40°C. If an attempt is made to charge the battery outside this temperature range, the battery's automatic system will automatically switch off the charging process. The battery reaches its maximum service life if it is charged at temperatures between 10°C and 30°C.
- Only use the chargers intended for charging the battery. Information on this can be obtained from your specialist dealer.
- Using an unsuitable charger can lead to malfunctions and reduce the service life of the battery. There is also a risk of fire and explosion.
- Once the charging process is complete, the charger must first be disconnected from the mains socket and then from the battery.
- Ensure sufficient air circulation as soon as the battery is being charged.
- Only charge the battery under supervision.
- Damaged batteries must neither be charged nor used.
- Damaged chargers (damage to plug, housing, cable) must not be used.

11.4.4 Safety and Warnings for Transporting and Shipping the Battery Pack

Lithium-ion cells are used in the Neodrive battery. Therefore, there are legal requirements for the transport and shipping of the battery, which must be strictly adhered to. For example, a defective battery may not be transported by air.

If your battery is faulty, please take it to your retailer in person, as shipping by post or other means is also strictly regulated for lithium-ion batteries. Again, we recommend that you contact your retailer in advance.

As transport regulations can change from year to year, we strongly recommend that you check with your tour operator, airline or shipping company for the current regulations before travelling. A defective battery cannot be taken on board an aircraft or checked in as luggage. If your battery is attached to the pedelec during transport, simplified transport conditions apply in accordance with UN3171.



Keep the battery box in case you need to transport the battery.



Discuss transportation with your dealer before shipping.

11.4.5 Safety and warning information on the charger



Before starting the charging process, read and observe all instructions and warnings enclosed with the charger as well as the following warnings and safety instructions.

- To charge the battery, use only the charger provided. For more information, contact your dealer.
- Use of an unsuitable charger may result in malfunction and reduced battery life. There is also a risk of fire or explosion.
- Charging stops automatically when the battery is fully charged. Overcharging is therefore impossible.
- When the charging process is complete, we recommend that you disconnect the charger from the mains supply and then disconnect the battery.
- Never use a charger other than the one recommended by your dealer.
- Do not expose the charger to moisture (water, rain, snow) during the charging process.
- Never charge in rooms where moisture may condense on the charger.
- Beware of condensation. If the charger is brought from a cold room into a warm room, condensation may form. Do not use the charger until the condensation has evaporated. This can take several hours.
- Never carry the charger by the mains or charging cables.
- Never pull on the mains cable to disconnect the charger from the wall socket.
- Do not apply pressure to cables and plugs. Excessive stretching or kinking of the cable, pinching a cable between a wall and a window frame, or placing heavy objects on a cable or plug may result in an electric shock or fire.
- Route the mains cable and the attached charger cable in such a way that they cannot be walked on, tripped over or subjected to other harmful influences or stresses.
- Do not use the charger if the mains cable, the charging cable or the plugs attached to the cables are damaged. Damaged parts must be replaced immediately by an authorised dealer.

- Do not use or disassemble the charger if it has been subjected to a hard blow, dropped or otherwise damaged. Take the damaged charger to an authorised dealer for repair.
- Do not allow small children to use the charger.
- Do not disassemble or modify the charger.
- Do not cover the charger or place any objects on it while it is charging.
- Never short-circuit the poles of the charger plug with metal objects.
- Ensure that the mains plug is firmly inserted into the socket.
- Do not touch the plugs with wet hands.
- Do not use the charger plug and/or mains plug if they are wet or dirty. Clean the plugs with a dry cloth before connecting them.

11.5 Getting started

11.5.1 About the operating modes

There are two basic operating modes for the battery. The battery is either in 'Active Mode' or in 'Deep Sleep Mode'. In 'Active Mode' the battery consumes at least 5 mA per hour (self-consumption of the electronics). To minimise power consumption, the battery automatically switches to 'Deep Sleep Mode' after 48 hours.

Inserting the battery

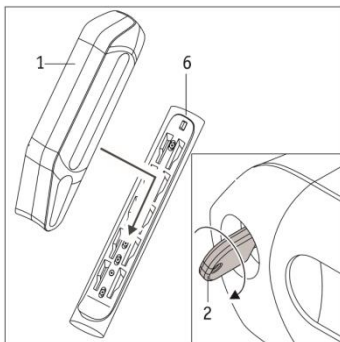

- Place the battery [1] on the battery rail [6] mounted on the pedelec.
- Slide the battery [1] to the front edge of the battery rail [6] as shown in the diagram.
- Lock the battery [1] by carefully turning the key [2] clockwise as far as it will go. The battery can now no longer be removed from the battery rail.
- Remove the key [2] from the battery [1].

11.5.3 Connecting the battery to the engine cable

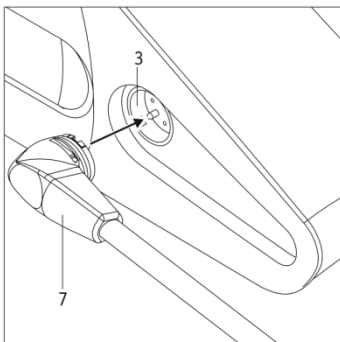

- Insert the plug [7] of the cable coming from the motor into the socket [3] on the battery [1].
- The two parts are automatically aligned and locked correctly by a magnetic lock.

Before inserting the plug [7] into the socket [3], make sure that both parts are clean and that there are no metallic particles inside. If these are present, they must be removed with a clean, dry cloth.

11.5.4 Switching on the battery

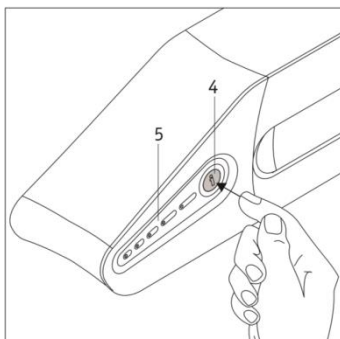

If the battery has been used within 48 hours, it does not need to be switched on. The pedelec is ready for use and can be switched on and put into operation via the sMMI.

If the battery is being used for the first time or has not been used for more than 48 hours ('deep sleep mode'), it must be switched on.

- Briefly press the button [4].
- Switching on is indicated by all LEDs [5] flashing three times.
- Your Pedelec is now ready for operation and can be switched on and commissioned via the sMMI.

i If the motor cable is not yet connected to the battery, the battery will still be switched to 'Active Mode' when it is switched on.

i If the battery cannot be switched on, the cell voltage may be too low. In this case connect the charger and press the on/off button [4]. The battery will then be charged for one minute.

11.5.5 Charge status indicator

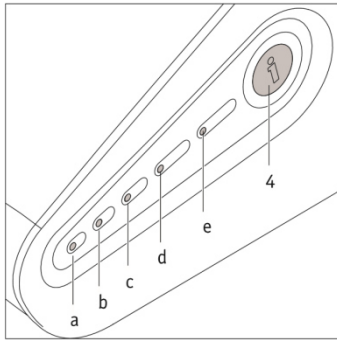

You can check the battery charge status at any time using the LED indicator. If the battery has not been used for more than 48 hours:

- Briefly press button [4].
- The battery is switched on, all LEDs (a to e) flash three times.
- Briefly press button [4] again.
- The capacity of the battery is now indicated by the LEDs as shown in the table below. Tabelle

Has the battery been used in the last 48 hours:

- Briefly press button [4].
- The capacity of the battery will now be indicated by the LEDs as shown in the table below.

LED on	LED flashes	Capacity
-	a	< 19%
a	-	20 – 39%
a, b	-	40 – 59%
a, b, c	-	60 – 79%
a, b, c, d	-	80 – 99%
a, b, c, d, e	-	100%

i The display may vary slightly depending on the battery cell used.

11.6 Removing the battery

11.6.1 Switching off the battery

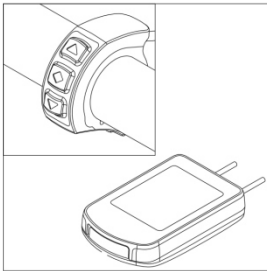

The battery is switched off using the sMMI controller (see neodrives sMMI and motor instruction manuals). To do this, the battery is first set to 'Active Mode' for 48 hours. This means that the sMMI can be reactivated at any time during this period without having to switch on the battery first. The power consumption is minimal.

11.6.2 Disconnect cable connection

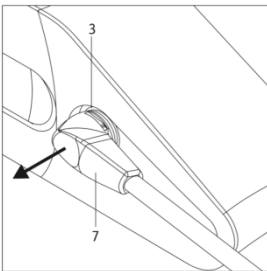

- Switch off the Pedelec at the sMMI.
- Then pull the plug of the motor cable [7] out of the socket Buchse [3].



Ensure that the motor cable plug [7] does not come into contact with any metallic particles when it is removed (risk of contamination).

11.6.3 Removing the battery

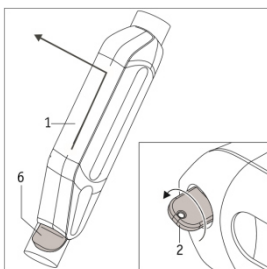

- Insert the key [2] into the latch on the battery [1].
- Gently turn the key [2] anti-clockwise as far as it will go. The lock is now released and the key cannot be removed from the battery.
- Pull the battery [1] upwards along the rail [6] for about 2 cm and then remove it completely.
- Keep the battery in a clean place.



Make sure that the socket [3] does not come into contact with any metallic particles when you put the battery down (risk of contamination).

11.7 Charging the battery

Fully charge the battery before first use. The battery is normally supplied at 30% charge. The battery can be charged to any state of charge without affecting its life. The battery will reach its maximum life when charged at an ambient temperature between 10°C and 30°C.

11.7.1 Connecting the charger

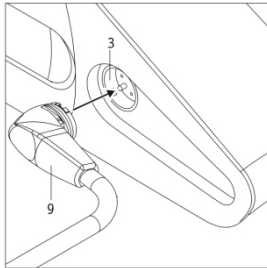

The battery [1] does not need to be removed from the pedelec for charging, but can remain attached. Only the motor cable plug [9] needs to be removed (see chapter 4.2). Then proceed as follows.

- Insert the plug [9] of the charger into the socket [3] on the battery.
- The correct alignment and locking of the two parts is done automatically by a magnetic lock.
- Carry out the charging process in accordance with the charger operating instructions. Also observe the notes on the charging process in chapter 2.3.



Before inserting the plug [6] into the socket [3], make sure that both parts are clean and that there are no metallic particles inside. If these are present, they must be removed with a clean, dry cloth.

11.7.2 Charging procedure

Follow the instructions in the charger operating manual when charging the battery. Also observe the safety instructions and warnings in sections 2.3 and 2.5.

11.7.3 LED indicators during charging

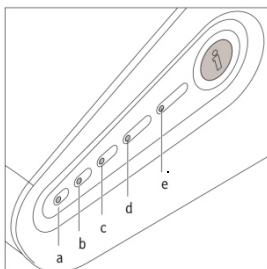

The following table shows the LED display [5] of the battery during the charging process.

LED on	LED flashes	Capacity
-	a	< 19%
a	b	20 – 39%
a, b	c	40 – 59%
a, b, c	d	60 – 79%
a, b, c, d	e	80 – 99%
a, b, c, d, e	-	End of charging reached, battery 100% charged

- i** The display may vary slightly depending on the type of battery being used.
- i** If an error occurs during charging, all the LEDs will light up. Check that all criteria (e.g. ambient temperature, correctly connected charger plug, etc.) for the charging process are met in accordance with this and the operating instructions supplied with the charger.
- i** Do not leave the charger connected to the mains for longer than is necessary for the charging process. After charging, the charger must be disconnected from the mains first and then from the battery.
- i** Always check the charge level of the battery before starting a journey. It should be fully charged before driving to ensure that the power assistance is available at all times.
- i** The battery should only be charged in a dry room at a temperature between 0° and 40° Celsius maximum.
- i** Follow the instructions in the manual supplied with the charger.
- i** Follow the safety instructions and warnings for the battery in chapters 2.1 to 2.5 of this manual.

11.8 Key

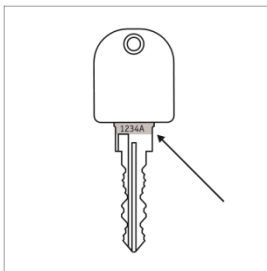

The battery pack comes with two keys for locking it in the battery holder. Your dealer should note the engraving on the key in the documents supplied with the pedelec so that they can be re-ordered if necessary. Please check that the key marking is recorded in the papers. If it is not, please add it. Keys can only be reordered from AXA dealers (as at October 2017).

11.9 Cleaning the battery

Never use petrol, thinner, acetone or similar products for cleaning. Only use commercially available household cleaners and disinfectants (isopropanol).

- The charger cable plug [9], the motor cable plug [7] and the battery charging socket [3] should only be cleaned with a dry cloth.
- Under no circumstances should the battery be sprayed with a steam jet or similar.

11.10 Disposal



Electrical and electronic equipment must be disposed of separately from general household waste at designated government centres. Proper disposal and separate collection of waste equipment helps prevent potential harm to the environment and human health. It is a prerequisite for the reuse and recycling of used electrical and electronic equipment. For detailed information on how to dispose of your old equipment, please contact your local authority, your household waste disposal service, the shop where you purchased the product or your sales contact. This information applies only to products installed and sold in European Union countries and covered by European Directive 2002/96/EC. In countries outside the European Union, other regulations may apply to the disposal of electrical and electronic equipment.

11.11 Liability

The manufacturer's liability is excluded in all cases where

- the battery has been mishandled.
- the battery has been used contrary to the instructions in this manual.
- the battery has been used with an insufficient charge.
- repairs or other work have been carried out by unauthorised persons.
- the battery has been used contrary to its intended use.

12 | CHARGER

12.1 General safety information



Read the instruction manual carefully before use.

There is a risk of fire, explosion and corrosion if lithium batteries are mishandled. Always follow the battery manufacturer's instructions.



Only charge Li-ion batteries. Do not charge lead, NiCd, NiMH or non-rechargeable primary cells.



Only connect the charger to suitable power sources. If the unit is not to be used for an extended period of time, disconnect the power supply and any connected batteries.



This appliance may be used by children from 8 years of age and by persons with reduced physical, sensory or mental capabilities or lack of experience and knowledge, if they have been given

supervision or instruction concerning the safe use of the appliance and have understood the hazards involved. Do not allow children to play with the appliance. Do not allow children to clean or service the appliance without supervision.



The charger is designed to operate in a ventilated, dry and dust-free environment. Do not expose the charger to rain or extreme heat. Do not cover the unit.



Keep the charger clean and dry.



Do not charge an overheated battery until it has cooled down to ambient temperature.



Stop charging if the battery pack becomes too hot (>55-60°C).

Do not use the charger if it is damaged. Do not open or modify the charger. Repairs should only be carried out by authorised personnel using original spare parts.

12.2 Charger functions

1. This charger is suitable for charging a 36V nominal Li-Ion battery pack, 10 Li-Ion cells in series. The charging current is max. 4 A. The maximum capacity of the battery can be up to 25 AH.

2. The charger is protected against overcurrent, short circuit, overvoltage and reverse polarity. Over-current protection (disconnects when the output current exceeds 7A) Short-circuit protection (disconnection in the event of a short circuit on the DC side) Overvoltage protection (disconnection when the output voltage exceeds 50V) Reverse polarity protection (shutdown if a battery with the wrong polarity is connected to the charger cable)

3. the charger has an additional capacity counter which stops charging after 25Ah has been charged. This is indicated as a fault.

4. the unit has a temperature monitor which protects the unit if the ambient temperature is too high or if it is permanently overloaded. In this case the output power is reduced.

5. the red LED flashes in the event of a fault.

12.3 Operation

1. Before using the charger for the first time, check that the parameters of the charger and your battery match, using the information on the rating plate or the documentation supplied.

2. Check that the mains voltage is suitable for the charger.

	Minimum	Nominal	Maximum
Input voltage (Volt)	207	230	264

3. To check that the charger is working properly, plug it in. The green LED will flash slowly when ready.

4. Connect the charging cable (DC cable) to your battery. The green LED will flash evenly to indicate that charging has started. If the battery voltage is too low (<25VDC), the battery will be charged with a precharge current of approx. 500mA. The green LED flashes evenly. This process takes a maximum of 30 minutes. If the voltage threshold of 25VDC is not exceeded during this time, the charger switches off, indicating a battery fault. The charger indicates a fault. In this case, contact the battery supplier. When 25V is reached, the charger automatically switches to fast charging.

5. When the battery is fully charged, the charger switches off. The green LED will remain lit to indicate that the battery is fully charged. In the case of single battery packs, the charging process starts again after approximately 2 seconds, but switches off again shortly afterwards. This can be repeated continuously. This will not damage the battery.

6. The unit is equipped with a temperature monitor which protects the unit if the ambient temperature is too high or if it is permanently overloaded. In this case, the output power is reduced until a stable operating temperature is reached.

Status	LED indicator			
	LED red		LED green	
Readiness	off	●	slowly flashing 10%	⚡
Summoning	off	●	flashing 50%	⚡
Charging proces	off	●	flashing 50%	⚡
Fully charged	off	●	continously (approx. 2sec.)	○
Malfunction	flashing	⚡	off	●

End of charge voltage 42 V +/-1%

12.4 Notes

The charger has reverse polarity protection. Correct connection to a battery is a prerequisite for the charger to generate an output voltage. If the battery has been discharged below its nominal final discharge voltage, it is possible that the battery can no longer be charged. In this case, please contact the battery manufacturer. Errors caused by exceeding the capacity counter or the pre-charge time are reset as soon as the battery is removed. Faults caused by short circuits or incorrect polarity are automatically reset a maximum of 1 minute after the fault has been rectified.

12.5 Scope of delivery

1. charger with charging cable
2. AC power cable with plug
3. quick reference guide

13 | NOTES AND TROUBLESHOOTING

13.1 Cleaning

Never use benzine, thinner, acetone or similar products for cleaning. Do not use abrasive or aggressive cleaning agents. Instead, use only commercially available household cleaners and disinfectants (isopropanol). The display should only be cleaned with a damp cloth. Never use benzine, thinner, acetone or similar cleaning agents. Do not use abrasive or aggressive cleaning agents. The engine of your pedelec should be cleaned regularly, preferably with a dry brush or a damp (not wet) cloth. It should not be cleaned with running water, such as a hose or a high-pressure cleaner. However, you can ride in the rain and on wet roads. Penetrating water can damage the engine. Therefore, always ensure that no liquids or moisture enter the engine when cleaning. Do not clean the engine when it is hot, for example immediately after a ride. Wait until it has cooled down. Otherwise damage may occur. If the engine is removed, e.g. for cleaning, it must never be held or carried by the cables as there is a risk of the cables breaking. If the motor has been removed from the frame of the pedelec, the plug and socket of the cable to the battery pack must be disconnected first. If the motor has been removed from the frame of the pedelec, the plug and socket of the cable to the battery pack must be checked for possible contamination and cleaned before reassembly.

13.2 Transportation

When transporting the handlebar-mounted simplyRemote by car, the following instructions must be observed:

- Take appropriate measures to protect all the components of your pedelec from moisture and dirt.
- Make sure that the cables are not bent.
- Remove the battery and the sMMI from the bike before attaching the pedelec to your car's luggage rack. This will also reduce the weight you have to lift, especially with a roof rack system.
- Always transport the battery and sMMI in the passenger compartment of your car.
- The sMMI and battery should also be removed when transporting in the passenger compartment (e.g. in a station wagon) to avoid damage during loading and driving.
- For carrier systems with a down tube clamp, ensure that the battery mounting rail is not crushed/damaged when the clamp is tightened.
- After each ride, check all contacts on the pedelec for foreign objects or moisture. To ensure safe operation, all connectors must be free of dirt and foreign objects and completely dry.
- When transporting your pedelec, e.g. in the boot of a car, never place it on the side of the simplyRemote. This could damage it.

13.3 Fault symptoms and possible measures

Error	Troubleshooting
E-bike does not pair with the <i>simply-Ride</i> App	Close the app, switch off the e-bike via the <i>simplyRemote</i> and remove the <i>simplyRemote</i> /e-bike from your Bluetooth devices on the smartphone. Reconnect to the e-bike.
Bike data such as framenumber is not saved.	Are location and Bluetooth activated? The e-bike is not connected to the app.

13.4 Warnings on the *simplyRemote*

Colour	Indicator		Troubleshooting
Warning			
Orange, flashing	○ ○ ○ ○ ○	Battery charge <5%	Charge battery
Orange, flashing	○ ○ ○ ○ ○	Torque sensor motor	Do not press the pedal for 1 second
Update			
Ascending flashing	○ ○ ○ ○ ○	Update procedure	LEDs flashing in ascending order (in different colors depending on the component) indicate the update process. During this time, the motor does not provide support and the system must not be moved. The update process takes a maximum of 15 minutes and then you can use your e-bike as usual.

13.5 Error symptoms

<p>The system cannot be switched on (no indication on the sMMI display)</p>	<ul style="list-style-type: none"> - Is the battery correctly inserted in its holder? - Are all plugs connected correctly? - Are there any deposits (e.g. metal shavings) on the magnetic connector on the battery? please check this very carefully! - Is the battery “woken up”? <p>The battery goes into “deep sleep” after 48 hours of non-use and must be reactivated by pressing the battery button once.</p> <ul style="list-style-type: none"> - Has the sMMI-Lock been activated by the specialist dealer? <p>If so, the sMMI will only work with the motor intended for it.</p> <ul style="list-style-type: none"> - Do the sMMI contacts on the dock spring back cleanly? <p>Press the 8 pins individually into the dock with your finger. Check whether the pins spring back. Eliminate any jamming with contact spray.</p>
<p>The battery cant be charged.</p>	<ul style="list-style-type: none"> - Are there any deposits (e.g. metal shavings) on the charger's magnetic plug? Carefully check the plug of the charger and the socket of the battery for deposits. - Is the ambient temperature <0°C? <p>The battery cannot be charged below 0°C. Always charge the battery at room temperature.</p> <ul style="list-style-type: none"> - Observe the information on the charging process, in particular the error codes, in the operating instructions for the charger.
<p>No motor support (sMMI in operation, motor support not available)</p>	<ul style="list-style-type: none"> - First check that the motor cable and motor plug are correctly aligned with each other. - Does an error message appear on the display? <p>If so, follow the relevant recommendations.</p> <ul style="list-style-type: none"> - Has the switch-on routine been followed for the lighting? - Is the system permanently in recuperation mode? <p>If yes, check that the brake lever switch on the rear brake lever (only on sMMIs with brake cable) is correctly seated.</p> <ul style="list-style-type: none"> - Is the sMMI correctly attached to the dock?
<p>The recuperation/downhill assist does not work</p>	<ul style="list-style-type: none"> - Is the battery charge level > 90%? <p>Recuperation only works if the battery charge level is ≤ 90%.</p> <ul style="list-style-type: none"> - Is the current speed less than 15 km/h? No recuperation takes place below 15 km/h. - If the current speed is more than 28 km/h, recuperation is not possible above 28 km/h.
<p>Support levels cannot be changed when stationary</p>	<ul style="list-style-type: none"> - You have activated the push assistance in the menu. As soon as you start pedalling, you can select the assistance levels. Alternatively, you can deactivate the pushing aid again via the menu.
<p>The motor does not deliver full power</p>	<ul style="list-style-type: none"> - The motor may be in the high temperature range. <p>From 80°C electronics temperature, the power is gradually reduced. Allow the pedelec to cool down for approx. 10 minutes (in the shade) and then resume riding.</p> <ul style="list-style-type: none"> - As the battery voltage decreases, the power and the maximum speed also decrease slightly. With an almost empty battery, the maximum speed may be 2-3 km/h lower than when riding with a fully charged battery.
<p>The symbol for the service reminder (chapter 3.2.11) is shown on the display.</p>	<p>You can continue to ride your pedelec without any restrictions. However, please arrange a service appointment with your specialist dealer. They can then reset the display.</p>



1 MOERS

2 WICKEDE

3 DRESDEN

4 NÜRNBERG

5 BAD MERGENTHEIM

6 GERLINGEN

7 GÖPPINGEN

8 GEISLINGEN

9 REUTLINGEN

10 MÜNCHEN

ALBSTADT
Production



www.neodrive.com



Our e-bike brands

Alber GmbH
Vor dem Weißen Stein 14
72461 Albstadt
Telefon 07432 2006-0
info@alber.de